

KNAPHEIDE

SINCE 1848



CRANE BODIES

KNAPHEIDE CRANE BODIES

Knapheide Crane Bodies are purpose-built to hold up under the most extreme of lifting conditions.

With all the industry-leading security and durability features of our Service Bodies, the Knapheide Crane Body is an easy choice.

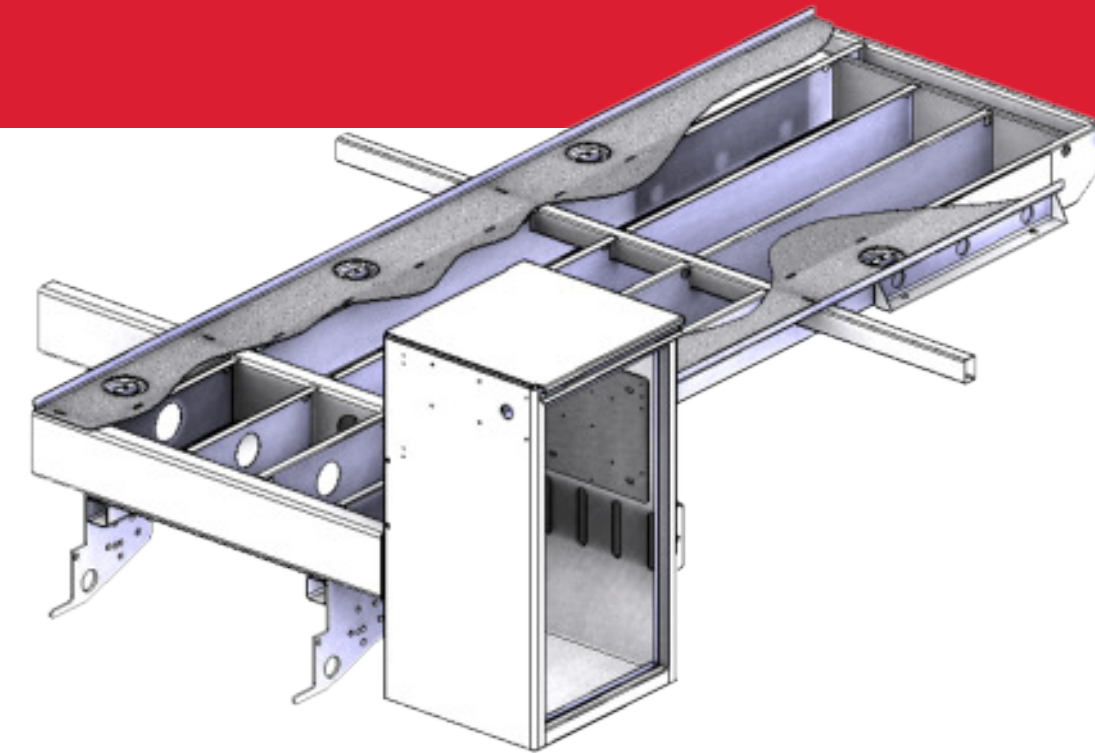
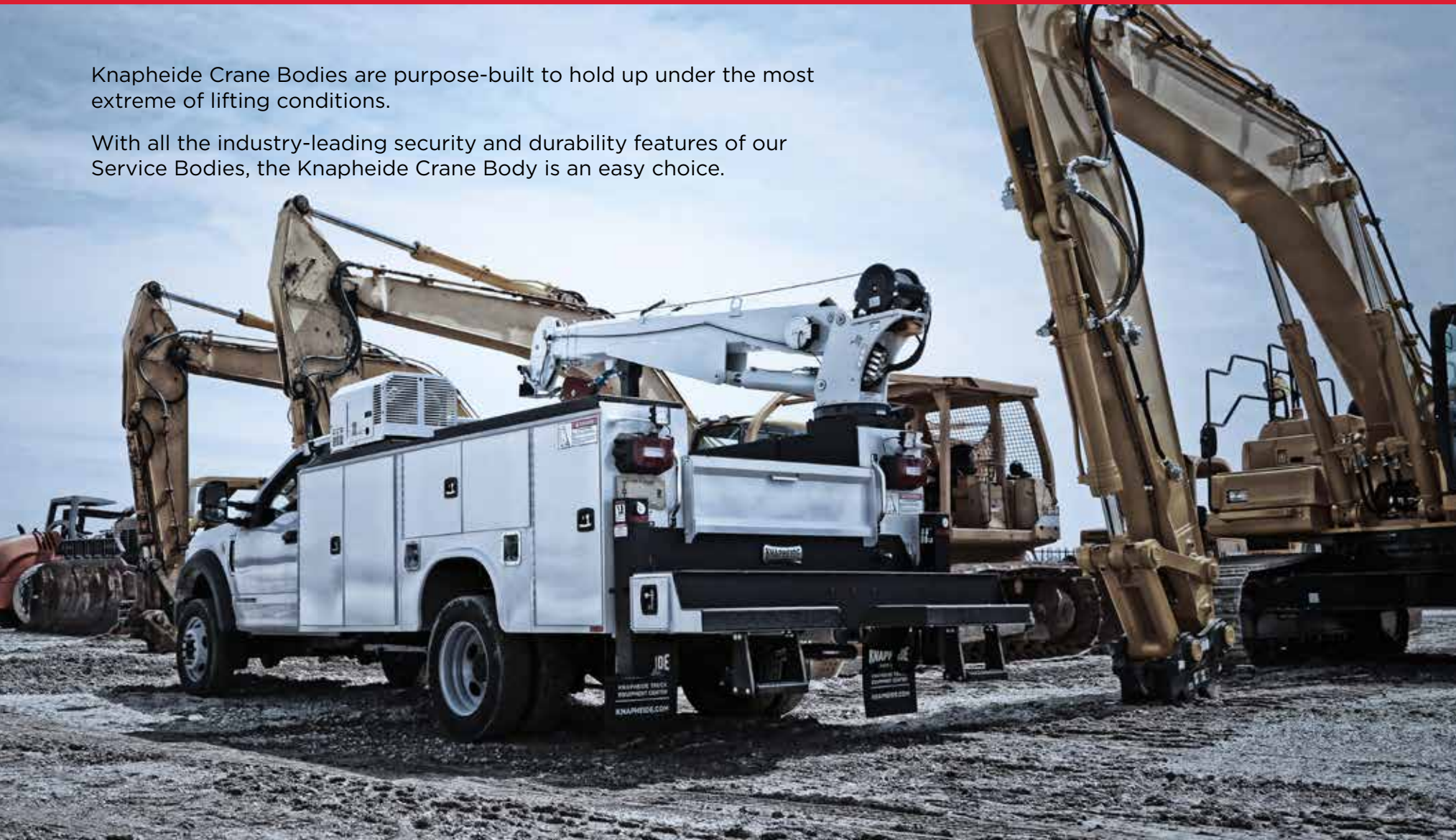

CRANE BODY UNDERSTRUCTURE

Knapheide 44 and 60 Crane Bodies feature our unique torq-isolator crane support system. The reinforced crane box transfers lift forces into the full-length torsion-box subframe and outriggers, not the side compartments.

-44 AND -60 MODELS

Knapheide 44 and 60 Crane Bodies are built with heavy lifting in mind. The 44 bodies are designed to support a maximum crane rating of 44,000 ft-lb., while the 60 support a maximum crane rating of 60,000 ft-lb. with ease. Both are designed to handle the rigors of your everyday extreme lifting using a unique torq-isolator support system understructure.

-30 MODELS

With the storage and efficiency of a service body, the Knapheide 30 Crane Body is specifically designed and reinforced to support up to a 30,000 ft-lb. crane. This versatile size and functionality makes it an easy choice for field applications.

POPULAR VOCATIONS



HEAVY
CONSTRUCTION



AGRICULTURE



PREVENTATIVE
MAINTENANCE



OIL/MINING/GAS

A. DOUBLE PANELED DOORS
made of galvanized steel (14-gauge outer panel, 20-gauge inner panel) are reinforced with internal braces for durability

B. 3-POINT T-HANDLE LATCHES
ensure your compartment doors stay closed and are individually lockable

C. OVERLAP DOORS
on front vertical and horizontal compartments

D. BODY SHELL
rugged 12- and 14-gauge two-sided A-40 galvanized steel

E. TWO CHROME GRAB HANDLES

F. INTEGRATED LED S/T/T AND B/U, LED STROBES
with (8) selectable patterns and built-in reflectivity mounted to external rear light boxes made of UV-resistant ABS material

G. BOLT-ON SLAMMABLE TAILGATE

H. RUBBER FENDERETTES
(model 6132DLHR-60 only)



FEATURES NOT SHOWN

SIDE WALL SHELF CLIPS
with 2" adjustable spacing

14-GAUGE INNER PARTITIONS OF COMPARTMENTS

COMPLETE UNDERCOATING
provides protection from corrosion and road debris

CARGO TIE-DOWNS
are D-ring type and recessed in floor, with a 6,000-lb. capacity (4 in 108" bodies, 6 in 132" bodies)

PRE-DRILLED MOUNTING HOLES
on crane pedestal for ease of installing most popular cranes

ELECTRODEPOSITION PRIME-PAINT SYSTEM
provides superior corrosion resistance

COMPARTMENT FEATURES



DOUBLE-SPRING OVER-CENTER RETAINER
on vertical compartment doors eliminate involuntary swing



NEOPRENE DOOR SEALS
protect compartments from the weather



COMPARTMENT INTERIOR
medium gloss, mar-resistant, light gray finish brightens interiors and makes finding contents easier



CONTINUOUS STAINLESS STEEL HINGES
are pry-proof and corrosion-resistant

REAR CRANE COMPARTMENT



FIXED SHELF
in crane compartment



DRIP PAN
located under crane mount



12-GAUGE BOTTOM AND END PANELS
applies to all compartments

A. REINFORCED REAR VERTICAL CURB SIDE COMPARTMENT

eliminates flexing and twisting of side packs

B. DOUBLE PANELED DOORS

made of 20-gauge galvanized steel are reinforced with internal braces for durability

C. AUTOMOTIVE-QUALITY, ROTARY-STYLE LATCHES

make opening and closing easy

D. BODY SHELL

rugged 12- and 14-gauge two-sided A-40 galvanized steel

E. TORSION BOX UNDERSTRUCTURE

design strengthens floor to resist flexing

F. INTEGRATED LED S/T/T AND B/U, LED STROBES

with (8) selectable patterns and built-in reflectivity for additional safety**

*Additional wire harness required for strobe lights
**Covered under 3-year limited warranty

G. BOLT-ON SLAMMABLE TAILGATE

H. EXCLUSIVE "RETURN FLANGE" FLOOR DESIGN

provides support, adds floor strength, and eliminates a rust-prone exposed seam between floor and side compartments

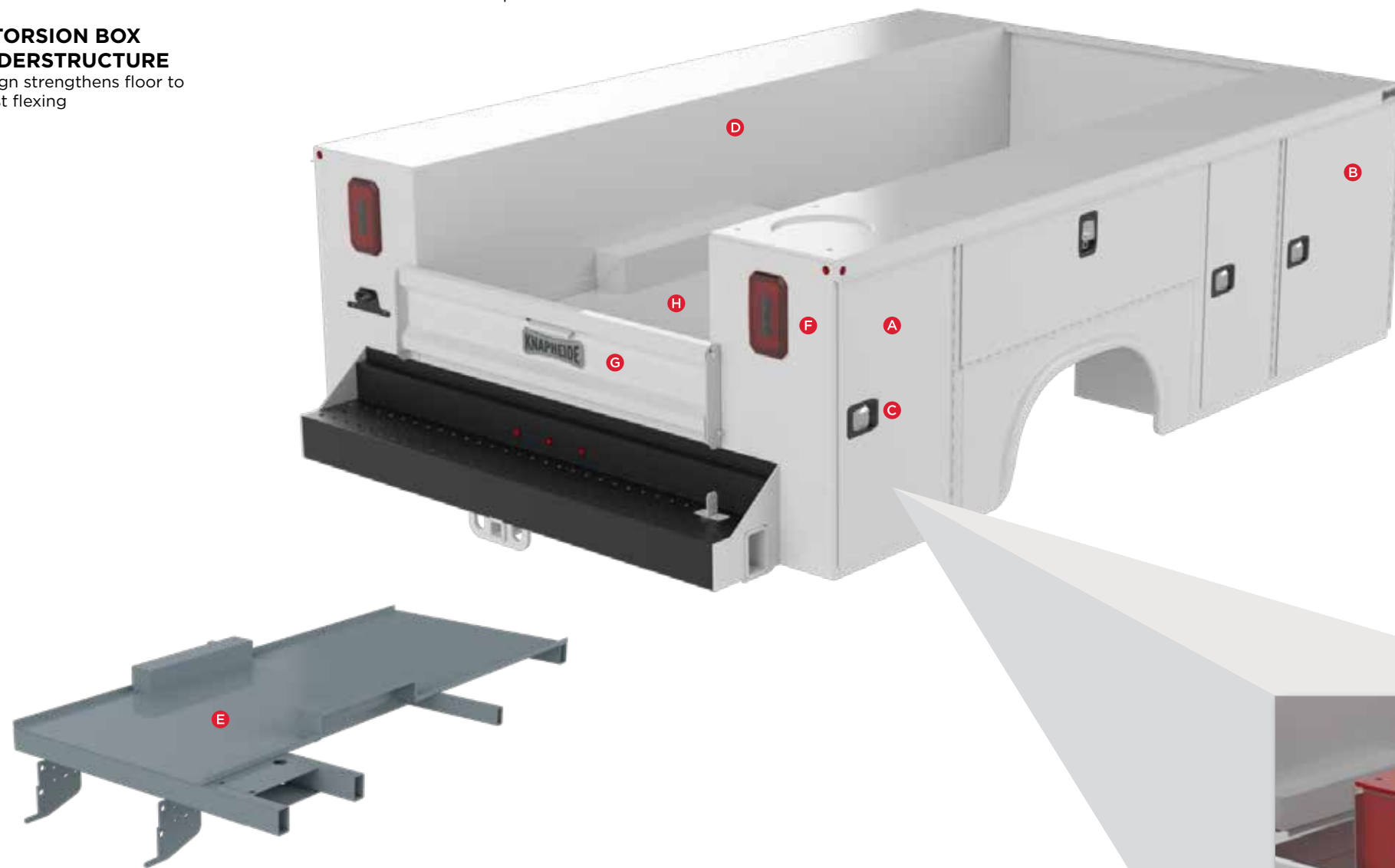

FEATURES NOT SHOWN

ELECTRODEPOSITION PRIME-PAINT SYSTEM
provides superior corrosion resistance

DRIP PAN
shipped loose for installation under the crane



DOUBLE-SPRING OVER-CENTER RETAINER
on vertical compartment doors eliminate involuntary swing



NEOPRENE DOOR SEALS
protect compartments from the weather



ADJUSTABLE DIVIDER SHELVES
250-lb. capacity



CONTINUOUS STAINLESS STEEL HINGES
are pry-proof and corrosion-resistant



INTERIOR LIGHT GUARDS
protect recessed lighting and wiring

CRANE REINFORCEMENT KIT

THE CRANE REINFORCEMENT KIT

allows you to incorporate a crane up to 4,000 lb. capacity (30,000 ft-lb. max.) onto the rear curb side corner of your body



REQUEST A QUOTE



Visit knapheide.com/quote and fill out the form to receive a quote and additional product information.

POPULAR OPTIONS

OPTIONAL SHELVING AND DRAWER PACKAGES

AVAILABLE FOR -44 AND -60 BODIES ONLY

1 Gas bottle retainer (2 bottles), vented top and bottom, (2) combination stationary/swivel hooks

For non-R models (no raised compartment), the bottle brackets are replaced with (2) adjustable divider shelves.

2 One shelf with (8) dividers each

3 Fixed shelf (standard)

4 Pull-out tray (500-lb. capacity), 3/4" plywood lined

5 (2) adjustable divider shelves with (4) dividers each

6 18-drawer cabinet and book rack

7 7-drawer unit: (1) 7", (3) 5", and (3) 3" on full extension slides with 250-lb. capacity

108 SERIES

PACKAGE A



PACKAGE B



PACKAGE C



132 SERIES

PACKAGE A



PACKAGE B



PACKAGE C



REQUEST A QUOTE



Visit knapheide.com/quote and fill out the form to receive a quote and additional product information.



POPULAR OPTIONS

BUMPERS

-44 AND -60 CRANE BODIES

The outrigger receiver bumper is a heavy-duty Galva-Grip bumper.

- Bumper and kick-plate are 12-gauge galvanized
- Grip tread punched into the step surface
- 4"x6"x3/8" outrigger receiver tube
- Features a 2" towing receiver hitch tube
(18,000lbs. max trailer, 1,800lbs. max tongue weight) DL
(30,000lbs. max trailer, 6,000lbs. max tongue weight) DLH



DL SERIES



DLH SERIES

-30 CRANE BODIES

- 21" deep step and work surface (DLH Series bumper has lower step, 5" deep)
- Grip tape supplied for step surfaces
- Through-compartment with door on each side (DL Series clear opening 6-3/4"x6-1/8", DLH Series clear opening 6-3/4"x8-1/8")
- Removable vise bracket with receiver tube
- Weight with receiver tube for crane: 438 lb. (DL Series), 611 lb. (DLH Series)



OUTRIGGER RECEIVER BUMPER

REQUEST A QUOTE



Visit knapheide.com/quote and fill out the form to receive a quote and additional product information.



POPULAR OPTIONS



ROCK GUARDS



CARGO TIE DOWNS

Already standard on 44 and 60 models



STEEL MECHANIC DRAWERS



LED COMPARTMENT LIGHTING



ALUMINUM DRAWERS



SORTIMO



MASTER LOCKING SYSTEM



GAS BOTTLE RETAINER

MODEL OPTIONS

-44 AND -60 CRANE BODIES

MODEL	BODY WEIGHT ¹	MAXIMUM CRANE SIZE	CHASSIS CA	CHASSIS MINIMUM GVWR	MAXIMUM TIRE SIZE
6108DL-44	2,629 lb.	6,000 lb. (44,000 ft.-lb.)	60"	15,000 lb. (17,500 for 6,000-lb. crane)	19.5" diameter rims, 34" tire diameter
6108DLR-44	2,689 lb.	6,000 lb. (44,000 ft.-lb.)	60"	15,000 lb. (17,500 for 6,000-lb. crane)	19.5" diameter rims, 34" tire diameter
6132DL-44	3,037 lb.	6,000 lb. (44,000 ft.-lb.)	84"	15,000 lb. (17,500 for 6,000-lb. crane)	19.5" diameter rims, 34" tire diameter
6132DLR-44	3,095 lb.	6,000 lb. (44,000 ft.-lb.)	84"	15,000 lb. (17,500 for 6,000-lb. crane)	19.5" diameter rims, 34" tire diameter
6132DLHR-60	3,186 lb.	10,000 lb. (60,000 ft.-lb.)	84"	19,000 lb. (27,000 for 10,000-lb. crane)	22.5" diameter rims, 46" tire diameter

¹Body weight does not include bumper or shelving

²Final determination of chassis specifications and minimum GVWR required for body, crane and other mounted equipment is the responsibility of the installer. See crane manufacturer's specifications for minimum chassis requirements.

-30 CRANE BODIES

MODEL	MAX CRANE RATING	CHASSIS CA	BODY LENGTH NOMINAL	BODY HEIGHT	BODY WIDTH	COMPARTMENT DEPTH	FLOOR WIDTH	NET WEIGHT
6108DL-30	30,000 ft.-lb.	60"	108"	40"	94"	20"	54"	2,306 lb.
6132DL-30	30,000 ft.-lb.	84"	132"	40"	94"	20"	54"	2,721 lb.
6132DLR-30	30,000 ft.-lb.	84"	132"	40"	94"	20"	54"	2,757 lb.

COMMITMENT TO CORROSION RESISTANCE

Corrosion won't be a concern when you buy quality Knapheide products. To give you the best corrosion protection, we utilize a state-of-the-art, custom-designed, 12-step, SST cathodic electrodeposition finishing system, called "E-Coat."

It bonds prime paint to steel by an electroplating process to give you a superior coat of primer, resulting in better corrosion protection compared to spraying methods.

This system allows us to create products with the highest level of corrosion resistance available.



FOLLOW US
LIKE US
TAG US



SIX YEAR, LIMITED TIME WARRANTY



**NO RUST
THROUGH**



**DOOR HINGES
WILL NOT FAIL OR
COME OFF BODY**



**LATCHES AND LOCK
CYLINDERS WILL NOT
FAIL TO OPERATE**



**SHELVES WILL NOT
BEND UNDER MAX.
LOAD OF 250 LBS.**

TO LEARN MORE VISIT
www.knapheide.com/warranty



NEVER SETTLE

If you are going to be a leader, it takes more than building a high-quality product. It means never being totally satisfied with that product, no matter how high quality it may be. It requires constant vigilance and a willingness to take a chance on something new. And it means exceeding expectations every time. As the industry changes, one thing never will—our commitment to making customers like you as productive and efficient as possible. We know you don't settle, and we don't either. That's why we want you never to settle for anything less than Knapheide on the back of your truck.

KNAPHEIDE. NEVER SETTLE.



The Knapheide Manufacturing Company
1848 Westphalia Strasse | Quincy, IL 62305
217-222-7131
www.knapheide.com