

# MASTERVOLT

THE POWER TO BE INDEPENDENT

## MLI Ultra

LITHIUM-ION BATTERY

12/3000, 12/6000, 24/6000



**CZONE**<sup>®</sup>



### USER AND INSTALLATION MANUAL

- (EN) For the latest version of this manual, visit our website:
- (NL) Ga om deze handleiding in andere talen te downloaden naar onze website:
- (DE) Um diese Anleitung in anderen Sprachen herunterzuladen, besuchen Sie bitte unsere Website:
- (FR) Pour télécharger ce manuel dans d'autres langues, consultez notre site Web :
- (ES) Para descargar este manual en otros idiomas, visite nuestro sitio web:
- (IT) Per scaricare questo manuale in altre lingue, visitare la pagina del prodotto sul nostro sito Web:

[www.mastervolt.com](http://www.mastervolt.com)

## Table of contents

1. SAFETY INSTRUCTIONS .....	3	14. MASTERBUS ON THE MLI ULTRA.....	19
Warnings and symbols .....	3	Monitoring .....	19
Safety warnings.....	3	Alarms .....	20
Safety guidelines.....	5	History .....	20
2. LIABILITY.....	6	Configuration .....	20
3. WARRANTY.....	6	Events.....	23
4. LIFE CYCLES AND C-RATE.....	6	Events sources .....	24
5. CORRECT DISPOSAL OF THIS		Event commands .....	24
PRODUCT .....	6	Stop charge event.....	25
6. PRODUCT DESCRIPTION .....	7	Battery safety event .....	25
Introduction .....	7	How to activate MasterBus powering ...	26
Dimensions .....	7	15. CZONE® .....	27
Main parts .....	8	DIP switch settings.....	27
Protection .....	9	Network wiring .....	27
Identification label .....	9	Configuration .....	28
7. INSTALLATION.....	10	16. BUILDING A BATTERY BANK .....	34
Unpacking .....	10	Parallel connection.....	35
Check the battery .....	10	Series connection with one 48V	
Choosing a location to install.....	10	charger for two 24V batteries .....	37
Required tools .....	10	Set up clusters .....	39
Required materials .....	11	How to create a cluster in	
Charger settings.....	11	MasterAdjust.....	39
Installation drawing of a single unit.....	11	How to create a cluster in CZone.....	41
Safety relay .....	12	17. TROUBLESHOOTING .....	42
Installation procedure for a single unit .	13	18. TECHNICAL DATA .....	43
8. COMMISSIONING .....	15	Technical specifications .....	43
9. MAINTENANCE .....	17	CZone specifications.....	45
10. DECOMMISSIONING .....	17	Characteristics .....	45
11. REPLACEMENTS.....	17	DIP switch settings.....	47
12. STORAGE .....	17		
13. MASTERBUS.....	18		
About MasterBus.....	18		
How to set up a MasterBus network ....	18		
Network wiring.....	18		

## 1. SAFETY INSTRUCTIONS

### IMPORTANT SAFETY INSTRUCTIONS

#### SAVE THESE INSTRUCTIONS

##### Warnings and symbols

Safety instructions and warnings are marked in this manual by the following pictograms:



#### **CAUTION!**

Special information, commands and prohibitions in order to prevent damage.



#### **WARNING!**

A WARNING refers to possible injury to the user or installer or significant material damage to the MLI Ultra if the installer / user does not (carefully) follow the stated procedures.

##### Safety warnings



#### **WARNING!**

The battery contains hazardous materials that are stored safely during normal use. Do not crush, open or drop the battery housing. Do not touch or ingest any of the released materials or inhale released gasses when accidental leakage of the battery occurs. Should skin contact, eye contact or inhalation nevertheless occur, take the necessary first aid measures immediately. Refer to the Material Safety Data Sheet for Mastervolt Lithium-Ion batteries, which is available on [www.mastervolt.com](http://www.mastervolt.com).



#### **WARNING!**

Avoid short circuiting batteries as this may result in fire, explosion, electric shock or release of toxic gas. Use insulated tools only and keep metal objects away from the battery. Do not wear watches, bracelets, necklaces or other metal objects when working on the battery. In case of fire, take the necessary firefighting measures immediately. Refer to the Material Safety Data Sheet for Mastervolt Lithium-Ion batteries, which is available on [www.mastervolt.com](http://www.mastervolt.com).

**WARNING!**

Short circuits, too deep discharges and too high charge currents will damage the battery and may result in fire, explosion, electric shock or release of toxic gas.

**Always install an external safety relay!**

Never charge a battery:

- when the safety relay has cut out;
- after it was discharged below the Battery Safety voltage;
- when the battery is damaged;
- when the battery was overcharged.

If in doubt, contact your Mastervolt dealer.

**CAUTION!**

When transported, make sure that:

- the battery is in its original package or equivalent;
- the battery is in upright position;
- soft slings are used to avoid damage;
- nobody is standing underneath the battery during hoisting;
- the battery is only lifted at the handles;
- the battery is handled with care.

**Note:** The voltage range (12.0-14.6V or 24.0-29.2V) is larger than you may expect from other battery types such as lead-acid batteries. Be aware that these voltages could exceed the permitted voltages of the connected load(s).

## Warning regarding life support applications

Mastervolt products are not designed to be used as component of medical equipment, unless negotiated in the form of a written agreement between customer and/or manufacturer and Mastervolt. Such agreement will require the equipment manufacturer either to contract additional reliability testing of the Mastervolt parts and/or to commit to undertake such testing as a part of the manufacturing process. Furthermore, the manufacturer must agree to indemnify and not hold Mastervolt responsible for any claims arising from the use of the Mastervolt parts in the life support equipment.

### Safety guidelines

- Read this manual before using the MLI Ultra. Keep the manual in a secure place for future reference.
- Use the MLI Ultra following the instructions and specifications stated in this manual.
- Work on the MLI Ultra should be carried out by qualified personnel only.
- Non-compliance with operating instructions, repairs made with other than original parts, or repairs made without authorization render the warranty.
- Always install a safety relay which disconnects the battery under abnormal circumstances.
- If programming of events in a MasterBus network is required, the installer must be familiar with the programming of such events.
- Connections and safety features must always comply with all local rules and regulations.
- Use cables with an appropriate size.
- Never use the MLI Ultra in situations where there is danger of gas or dust explosion or potentially flammable products!
- Only use the MLI Ultra in a technical correct condition.
- Only use the MLI Ultra in a well-ventilated area and protect the connectors from moisture and dust.
- Switch off all charging systems and disconnect the MLI Ultra from the electrical installation during maintenance and/or repair activities.

## 2. LIABILITY

Mastervolt cannot be held liable for:

- Consequential damage resulting from the use of the MLI Ultra.
- Possible errors in the included manual and the consequences of these.
- Use that is inconsistent with the purpose of the MLI Ultra.

**Disclaimer:** Our products are subject to continual development and improvement. Therefore, additions or modifications to the products may cause changes to the technical data and functional specifications. No rights can be derived from this document. Please consult our online Terms & Conditions of Sale.

## 3. WARRANTY

The Mastervolt product warranty covers the MLI Ultra for the first two years after the purchase date, on the condition that the product is installed and used according to the instructions in this manual. Installation or use that does not comply with these instructions may result in under performance, damage or failure of the product and may void this warranty. The warranty is limited to the cost of repair and/or replacement of the product. Costs of labor or shipping are not covered by this warranty.

## 4. LIFE CYCLES AND C-RATE

The C-rate indicates how fast a battery can be (dis)charged. The capacity (C) of a battery is expressed in Ampere-hours (Ah) and the related charge/discharge capability is expressed in numbers that look like 1C, 2C, or C/2. A C-rate of C/2 is also known as 0.5C. A fully charged battery rated at 100Ah, provides 100A for one hour. The same battery discharging at C/2 provides 50A for two hours. At 2C it provides 200A for 30 minutes. Charge and discharge rates can have an impact on the number of life cycles. The MLI Ultra batteries offer 3500 cycles at 80% DoD at 25°C. To reach the specified number of cycles, we advise a maximum charge rate of C/3 and a discharge rate of C/2. This corresponds, roughly, to the following values:

	MLI Ultra 12/3000	MLI Ultra 12/6000	MLI Ultra 24/6000
Recommended discharge current	≤ 120A	≤ 240A	≤ 120 A
Recommended charge current	≤ 80A	≤ 160A	≤ 80A

## 5. CORRECT DISPOSAL OF THIS PRODUCT



This product is designed and manufactured with high quality materials and components, which can be recycled and reused. Act according to your local rules and do not dispose of your old products with your normal household waste. The correct disposal of your old product will help prevent potential negative consequences to the environment and human health.

## 6. PRODUCT DESCRIPTION

### Introduction

The MLI Ultra is a heavy-duty Lithium-Ion battery for running heavy loads for extended periods. The MLI Ultra consists of a waterproof electronics cabinet, with Lithium-iron phosphate cells.

### Dimensions

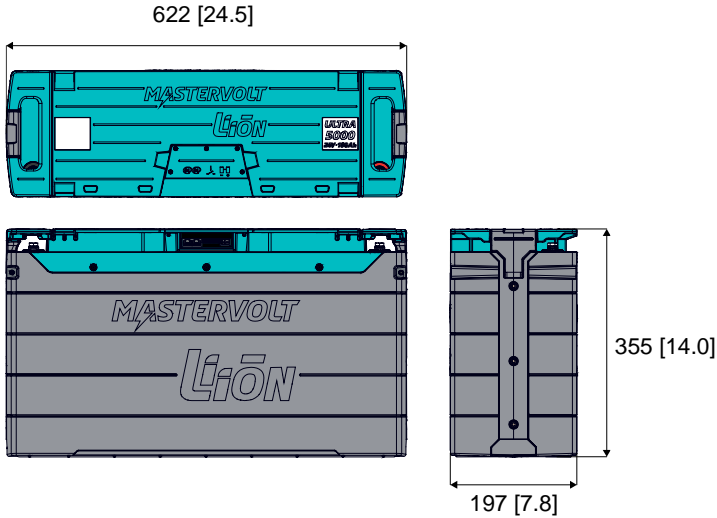

*Dimensions of the MLI Ultra 12/6000 and 24/6000 in mm [inches]*

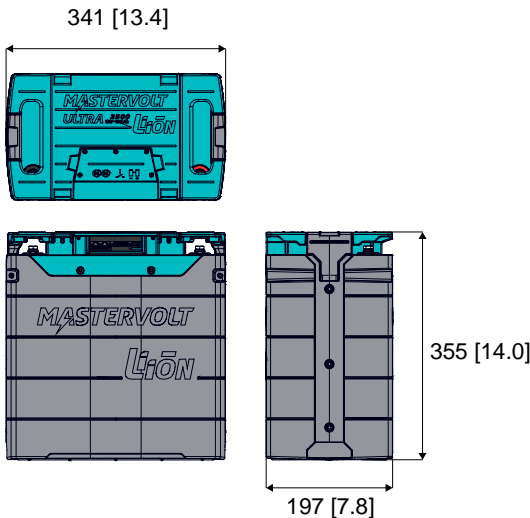

*Dimensions of the MLI Ultra 12/3000 in mm [inches]*

## Main parts

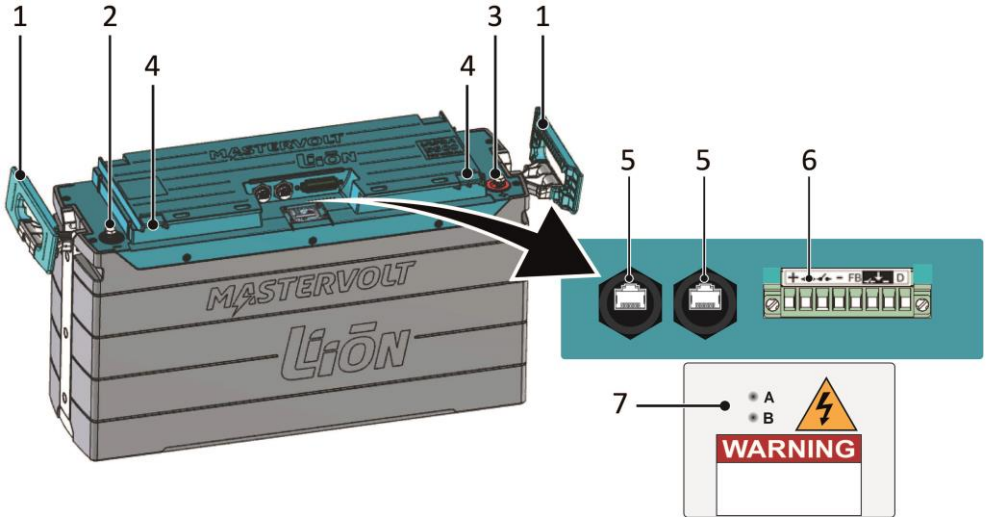

### Main parts

- 1 Tiltable handle for lifting
- 2 Negative battery terminal (M8)
- 3 Positive battery terminal (M8)
- 4 Mounting strap location
- 5 MasterBus / CZone connection (see sections Network wiring on pages 18 and 27)  
When waterproof protection is required, Mastervolt can also supply waterproof cable glands.
- 6 Battery Safety connector, see the Installation drawing on page 11 (single), 35 (parallel) or 36 (series)



(1) (2) (3) (4) (5) (6) (7) (8)

- (1) Relay Control (RC) positive (12/24V)
  - (2) Close relay pulse (12/24V)
  - (3) Open relay pulse (12/24V)
  - (4) RC minus (12/24V)
  - (5) FeedBack signal relay
  - (6) RC open relay from other battery
  - (7) RC minus from other battery
  - (8) Relay connector detect (connect to RC minus)
- 7 DIP switch cover and LED indicators
    - A (red): on indicates an unrecoverable error; contact your Mastervolt dealer.
    - B (yellow): 1 short blink, long pause; a low State of Charge;  
2 short blinks, long pause; CZone identification in progress;  
Steady blinking; firmware update in progress.

## Protection

The MLI Ultra is equipped with a Battery Management System (BMS). The BMS:

- balances the voltages between the cells;
- protects each cell from undercharging and overcharging;
- prevents too deep battery discharges;
- monitors the temperature of battery cells;
- communicates with Mastervolt charge devices over MasterBus or CZone;
- sends out warnings and alarms (to a display like the SmartRemote or EasyView 5 e.g.).

These protection and alarm features can be programmed as MasterBus events/CZone circuits, that display warnings or intervene on the electrical system.

## Identification label

The following picture is only an example!



The identification label is located on the top side of the MLI Ultra 6000 and on the back side of the MLI Ultra 3000. Technical information required for service and maintenance (part number aka product code, serial number and revision code) can be derived from the identification label.



### CAUTION!

Never remove the identification label.  
This will void the warranty.

## 7. INSTALLATION

For information on creating systems with multiple units in parallel or series, also see chapter 16.

### Unpacking

The delivery consists of the following parts:

- MLI Ultra battery
- MasterBus terminator
- Safety relay connector + jumper wire
- Drop cable CZone/MB (1m)
- 2x M8 bolt + washer + spring washer
- Mounting straps
- The user and installation manual

### Check the battery

Check the battery for possible damage and the open clamp voltage with a suitable voltage meter.

#### Allowed open clamp voltage

Model	Minimum	Maximum
12V	12.0V	14.6V
24V	24.0V	29.2V

Never use a damaged battery or a battery with an open clamp voltage that is out of range. If in doubt, contact your Mastervolt dealer. Optionally save the original packaging for future transport of the battery.

### Choosing a location to install





- Install the MLI Ultra in a well-ventilated room protected against rain, snow, spray, vapor, bilge, moisture and dust.
- Keep the MLI Ultra away from heat sources. See specifications for allowed operating temperatures.
- The MLI Ultra must be installed in upright position or on the long side, although upright mounting is recommended.
- Keep at least 1cm [3/8"] between two Li-Ion batteries for air flow.
- The MLI Ultra must be secured to its foundation with the two included straps.
- If the MLI Ultra is installed in a network, take the network powering into consideration.

### Required tools

- Hexagon socket wrench (13mm / ½")
- Flat blade screwdriver to fasten the relay wiring (2mm / 1/16")
- MasterBus USB interface
- Windows laptop or notebook with free MasterAdjust software or free CZone configuration tool. MasterAdjust software can be downloaded at [www.mastervolt.com](http://www.mastervolt.com)  
The CZone Configuration Tool software is available to technical CZone customers from the CZone Portal at [downloads.czone.net](http://downloads.czone.net)



**Note:** for safety reasons, the jumper wire is intentionally factory-set on pins 4 and 5, to generate an alarm and as a reminder to install the relay. To void the alarm: wire the relay and move the jumper wire to pins 4 and 8.

Safety relay connections			
Wire	Connect to (pin)	Description	
Red wire	 1	Relay Control (RC) positive	
Brown wire	 2	Close relay pulse	
Orange wire	 3	Open relay pulse	
Black wire	 4	RC minus	
Yellow wire	<b>FB</b> 5	FeedBack signal relay	
Jumper wire	<b>D</b> to  8–4	Relays connector detect, connect to RC minus	

## Safety relay

The use of a safety relay is a mandatory part of the battery installation. In our examples we use Blue Sea Systems' ML RBS Remote Battery Switch with Manual Control. If using a safety relay from another manufacturer, make sure that it offers the same contacts. In MasterAdjust/CZone Configuration Tool, select that you have another type than the ML switch, and configure accordingly.

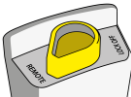
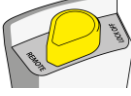
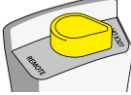
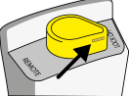

Blue Sea  
switch

Function	Description	Action	End position
REMOTE ON	To connect the MLI Ultra to load and charging devices	<ul style="list-style-type: none"> <li>- Rotate the knob to the left</li> <li>- Push the button down until latched.</li> </ul>	
REMOTE OFF	To disconnect the MLI Ultra from load and charging devices	<ul style="list-style-type: none"> <li>- Rotate the knob to the right to unlatch the button.</li> <li>- Rotate the knob to the left.</li> </ul>	
LOCK OFF	To prevent remote operation	Rotate the knob to the right.	
	To secure for servicing	With knob in LOCK OFF position, pass cable tie through hole.	

The safety relay will automatically open (REMOTE OFF) when built-in thresholds are met. See chapter 18 for details. The safety relay can also be driven by events (MasterBus) or circuit switches (CZone). This is explained further in the sections on events and circuits.

See also sections "Battery safety event" and "Non-resettable battery safety event", starting on page 25. For a CZone network, see also section "Configuration", starting on page 28.

It may be that the safety relay is mounted on top of the MLI Ultra. For example with an Ultra Connection Kit (product code 79007712 or 79007724), or as part of a Soft Start Module (SSM). The SSM is only used in 48V systems, where it is occasionally active to guarantee the lifespan of the safety relay.

### Installation procedure for a single unit



#### WARNING!

Always comply with all local rules and regulations.



#### WARNING!

Do not use a sensor for temperature compensated charging. Temperatures of the battery and its cells are monitored by the built-in BMS.

1. Switch off all loads and chargers.
2. Tilt the side handles to uncover the battery terminals.

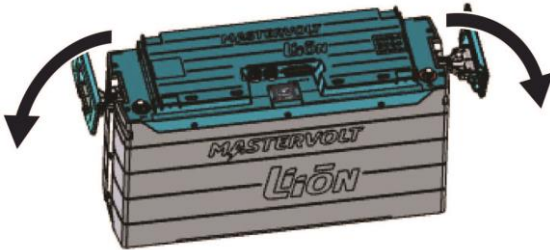

3. Integrate a fuse holder in the positive battery wire but do not place the fuse yet.
4. Set the safety relay knob to "LOCK OFF", see page 12.
5. Integrate the safety relay in the positive battery wire.

Disconnect the battery safety connector, item (6) in figure Main Parts on page 8, by loosening its screws. Connect the wires of the safety relay onto the battery safety connector as shown in the installation diagram on page 11 (see also chapter 16 in case of multiple units connection).

Replace the battery safety connector and fasten with the screws. Please note that if the wiring is not properly fastened, the safety relay will open.

6. Connect the DC main wiring, positive to +, negative to -.



#### WARNING!

In installations with a negative earth: Connect the negative cable last of all to prevent short circuiting.

**Note:** Use properly sized and reliable cables, cable lugs and battery terminals. Tighten all connections. For the main DC connections use 14.7 to 19.6 Nm / 130 to 170 InLbs torque. See the following illustration detail for the right order of placing the spring washer (A) and the flat washer (B).

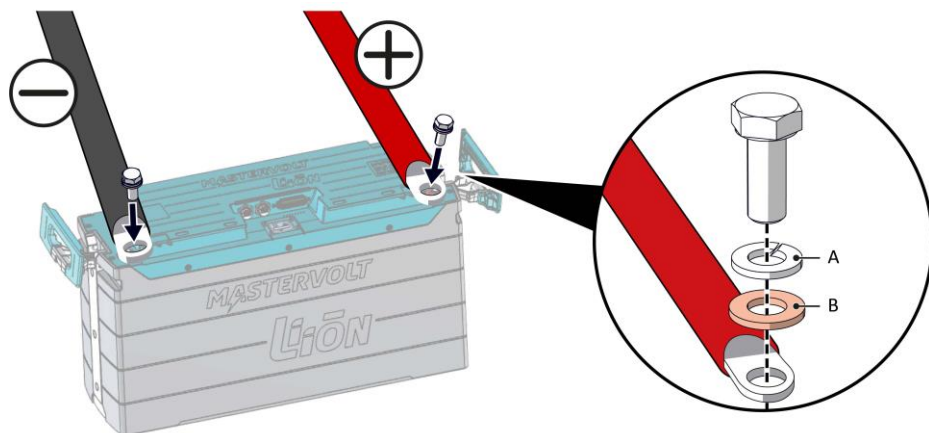

7. Close the side handles to cover the battery terminals again.
8. Connect the MasterBus/CZone cabling, see page 18/27.
9. Continue with the commissioning procedure, see next chapter.

## 8. COMMISSIONING

1. Check all wiring and connections. Do not place the fuses yet!
2. Set the safety relay to REMOTE OFF, see page 12.
3. Open MasterAdjust/CZone Configuration Tool, to configure the required events/circuits.



### WARNING!

If multiple charging devices are used to charge the battery (for instance both an AC powered charger and an alternator) then the **Stop charge** circuits/events must be configured for each charging device. In case of a multiple unit configuration, this must be done for each battery.

If an alternator is part of the charging system, configure the **Battery safety** event.

MLI Ultra event examples:

Summary	Monitoring	Alarm	Configuration	Events
<b>Events</b>				
Event 1 source	Event 1 target	Event 1 command	Event 1 data	
Stop charge	MCU Combi M	Charger	Copy Invert	
Event 2 source	Event 2 target	Event 2 command	Event 2 data	
Stop charge	MCU Combi S	Charger	Copy Invert	
Event 3 source	Event 3 target	Event 3 command	Event 3 data	
Stop charge	SCM Solar	On/Off	Copy Invert	
Event 4 source	Event 4 target	Event 4 command	Event 4 data	
Stop charge	APR Alpha Pro MB	Stop charge	Copy	
Event 5 source	Event 5 target	Event 5 command	Event 5 data	
Battery safety	APR Alpha Pro MB	Stop charge	On	

The settings depend on the used charger because different chargers have different state options. Check the manual of the used charger for how to switch the charging state.

Depending on the installation in which the battery is used, programming of additional circuits/events may be required.

For more information on MasterBus events see page 23.

For more information on CZone circuits see page 28 and following.

4. Test the safety relay (MasterAdjust only).

Go to the monitoring page of the (first) battery and click the **Close relay** button.

Check if the button on the safety relay goes down and stays latched (REMOTE ON).

Click the (last) battery's **Open relay** button.

Check if the button on the safety relay unlatches (REMOTE OFF). Keep the safety relay in this position.

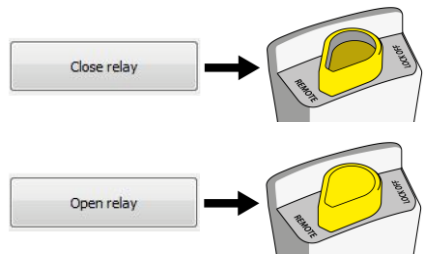

5. Install all fuses.

6. Verify that the current of the battery is 0A on the monitoring/metering page.
7. Switch on some loads.
8. Close the safety relay by setting the knob to REMOTE ON, see page 12.
9. Verify that a current is flowing out of the battery (negative value).
10. Switch off the load, then switch on the charger and verify that a current is flowing into the battery (positive value).
11. If necessary, check if MasterBus Power mode is on by making sure that DIP switch 2 is in the on position (see page 26). Note that this will slowly drain the battery.
12. Charge the battery fully until the charger switches to the float stage (maintenance charge).

Now the battery, or multiple battery system, is ready for operation.

## 9. MAINTENANCE

No specific maintenance is required. If necessary, use a soft, clean cloth to clean the MLI Ultra. Never use any liquids or acids.

For reliable and optimum function examine your electrical installation on a regular base, at least once a year. Defects such as loose connections, damaged wiring etc. must be corrected immediately.

## 10. DECOMMISSIONING

If it is necessary to take the MLI Ultra out of operation, follow the instructions in order of succession as described below:

1. Turn AC power off.
2. Disconnect all loads and charging devices.
3. Move the safety relay(s) in the LOCK OFF position, see page 12.
4. Disconnect all wiring.

## 11. REPLACEMENTS

If MLI Ultra batteries need to be replaced individually, make sure that the open circuit voltage of these batteries equals the voltage of the replaced or paralleled batteries.

In case of a MasterBus network: when exchanging charging devices that are used to charge the battery, the event configuration (such as the Stop Charge event), as well as other settings (such as charge voltage settings) needs to be redone for every new device.

## 12. STORAGE

The battery should be stored in a dry and well-ventilated environment. The rate of self-discharge is less than 5% per month. High or low ambient temperature affects the self-discharge rate of the batteries and natural aging.

If the battery will not be used for a period exceeding 3 months, we advise the following:

- If external AC power is available switch off all loads and switch on the charger. Apply a float voltage as specified in the following table.

Model	Float voltage setting
12V	13.5V
24V	27.0V

- If no external AC power is available:
  - Charge the battery to > 80% of its capacity before storage.
  - Set the safety relay knob to "LOCK OFF", see page 12.
  - Make sure MasterBus powering is not set to "Always on" (see Configuration tab in MasterAdjust).

In this setup the batteries can be kept at least 6 months without maintenance. However, it is highly recommended to charge the battery to > 80% of its capacity every 100 days.

## 13. MASTERBUS

### About MasterBus

All devices that are compatible with MasterBus are marked with the MasterBus symbol.

MasterBus is a CAN based, fully decentralized data network for communication between Mastervolt devices. MasterBus is used as power management system for all connected equipment, such as the inverter, battery charger, generator and many more.

Every device that is compatible with MasterBus is equipped with two data ports. The devices are simply daisy chained together, forming a local data network. Monitoring panels such as the SmartRemote or EasyView 5 can be used for monitoring and control of all connected MasterBus equipment.



#### CAUTION!

Never connect a non-MasterBus device to the MasterBus network directly! This will void warranty of all MasterBus devices connected.

### How to set up a MasterBus network

- Connections between the devices are made by standard straight MasterBus cables. Mastervolt can supply these cables.
- Up to 63 MasterBus devices can be interconnected.
- MasterBus needs a terminating device on both ends of the network.
- The electric power for the network comes from the connected devices according to the rule: 1 powering / 3 non-powering. Spread the powering devices over the network.
- Do not make ring networks.
- Do not make T-connections in the network.

For more details on MasterBus, please contact your Mastervolt dealer.

### Network wiring



- 1) Display
- 2) Charger
- 3) MLI 1
- 4) MLI 2
- 5) MasterBus Terminator
- 6) MasterBus Cable

### Adding the MLI Ultra to a MasterBus network

1. Disconnect a MasterBus cable or Terminator from the closest MasterBus device and connect it to the MLI Ultra.
2. Connect the new MasterBus cable to the other MasterBus device and then connect to the MLI Ultra.
3. Ensure that the network is properly terminated.

## 14. MASTERBUS ON THE MLI ULTRA

A display like the SmartRemote or EasyView 5, can be used to monitor the MLI Ultra. Advanced configuration can be done in MasterAdjust, from a Windows laptop or notebook connected to the MLI Ultra via a Mastervolt USB Interface. The following tables list the parameters as shown in MasterAdjust.

### Monitoring

Menu	Description
<b>Battery/Cluster</b>	
State of charge	Battery state of charge in %
Time remaining	Time of battery use left at the actual load in hh:mm:ss
Voltage	Battery voltage measured by the cell management system
Current	Current measured by the cell management system Positive value: charging, negative value: discharging
Temperature	Internal temperature of the battery in °C
<b>Relay</b>	
Relay close	Button to close the safety relay (connect).
Relay open	Button to open the safety relay (disconnect).
Relay state	State of the relay: open / close / not connected
Remote opened	Indication if the relay was opened by another connected MLI Ultra unit
<b>Installer</b> (you need to login as installer to see the following parameters)	
DIP switches	For CZone, the DIP switches 3 to 10 must match the unique address used in the CZone network
Battery safety	Indication of the occurrence of a Battery Safety event; see section Battery safety event on page 25
Stop charge	Indication of the occurrence of a Stop charge event; see section Stop charge event on page 24
Prediction>30min	This field is for troubleshooting. The Mastervolt dealer might ask for the status of this field if you contact them.
Reset safety	When the battery returns to normal conditions, use this button to reset the safety event. If this does not work, contact your Mastervolt dealer.
<b>Voltage</b>	
Cell 1 ... 8	Voltage of the individual cells
<b>Balancer</b>	
Balancer 1...8 act.	Indication of active balancing of the individual cells
<b>Temperature</b>	
Temperature 1, 2-3, 4-5, 6-7, 8	Temperature of the cells

## Alarms

Menu	Description
<b>General</b>	
Battery safety	Indication of the occurrence of a Battery Safety event; see section Battery safety event on page 25
Overcurrent	Battery current is >600A for more than 30 seconds. Reduce load immediately
Capacity low	This alarm is raised when the State of charge (SOC) drops below a preset value (10% by default)
Cap. Very low	Indicates that the State of charge drops below a preset value (0% by default)
Check relay	Indication to check the safety relay



## History

Menu	Description
<b>General</b>	
Cycle count	The number of cycles so far
Last time 100%	The number of days since the battery (bank) was charged up to 100%
Max. Ah used	The maximum used capacity that the MLI Ultra saw
UBat lowest	The lowest battery voltage that the MLI Ultra saw
UBat highest	The highest battery voltage that the MLI Ultra saw
Real SOC < 30%	Total amount of time that the SOC has been below this level. Note that the configured DOD (see next table) has no effect on these counters. Meaning that when the DOD is set to 80% and the displayed SOC is, for example, 5% then the real SOC is 25%. In this case, only the < 30% counter will increment.
Real SOC < 20%	

## Configuration

Menu	Description	Default	Adjustable range
<b>General</b>			
Name	Name of this device. This name will be recognized by all devices connected to the MasterBus network	MLI[serial number]	0-12 chars
Language	Menu language of this device	English	English, Nederlands
Serial number	Serial number of the MLI Ultra		(read only)
CZone enabled	This checkbox is marked when the MLI Ultra is setup to work in a CZone network	Off	(read only)
DIP switches	DIP switch state 0=off, 1=on	0000000000	(read only)
<b>Processor</b>			
Version	Firmware main version		(read only)
Revision	Product version		(read only)
Bootloader vers.	Firmware bootloader version		(read only)

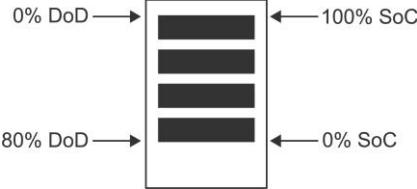
Menu	Description	Default	Adjustable range
<b>Relay</b>	See also chapter "Safety relay" on page 12		
Relay type	Safety switch type. In most cases ML Switch works well. Select Daisy chain only for the secondary battery in a series connection (i.e. NOT the battery to which the relay is connected to). Select Advanced if you are not using the ML Switch relay.	ML Switch	ML Switch, Daisy chain, Advanced
( <i>advanced only</i> ) Feedback type	Closed→closed: when the main contacts are closed, the feedback signal is Close. Closed→open: when the main contacts are closed, the feedback signal is Open.	Closed →open	Closed→closed, Closed→open, No feedback
( <i>advanced only</i> ) Pulse interval	The switching pulse width	500ms	5-500ms
<b>Cluster</b>	See also chapter "BUILDING A BATTERY BANK" on page 34		
Nr. in series	The number of batteries in series	1	1-10
Nr. in parallel	The number of batteries in parallel	1	1-24
Confirm topology button	Button to confirm the number of batteries in series and/or parallel		
Activate	Button to confirm the selected batteries		
<b>Event levels</b>			
Capacity low	Level below which the <i>Capacity low</i> event can be triggered	10%	0-100
Cap. very low	Level below which the <i>Cap. very low</i> event can be triggered	0%	0-100%
Battery full	Level above which the <i>Battery full</i> event can be triggered	100	0-100%
High temperature	Internal temperature of the MLI Ultra serves as an event source	45°C	30 - 60°C
Low temperature	Internal temperature of the MLI Ultra serves as an event source	5°C	-10 - 30°C
Voltage low	Level below which the <i>Voltage low</i> event can be triggered	12.5V 25.0V	12.25-12.75V 24.5-25.5V
Volt. low delay	Delay time to trigger the <i>Voltage low</i> event after the level was reached	10s	1-120s
Last time 100%	Last time fully charged serves as an event source. To get accurate SOC readings, regularly charge the battery to 100%.	31 days	7-60 days

Menu	Description	Default	Adjustable range
<b>Installer</b> (you need to login as installer to see the following parameters)			
DOD	To optimize the battery cycle life, the Depth of Discharge (DOD) is set to 80%. 	80%	20-100%
 <b>CAUTION!</b> Changing the DoD to 100% will decrease the cycle life.			
MB power	Off: MasterBus powering disabled. Automatic: MasterBus power will be switched off when the main current is in between 1.0A and -1.0A for more than 24 hours and the battery voltage has dropped below the float voltage. Always on: the MLI Ultra will power the MasterBus network. Note that this will slowly drain the battery. This option is only available if DIP switch 2 is in the ON position (see page 26).	Off	Off / Automatic / Always on
Factory reset	Button to reset the MLI Ultra to its default settings		
Test batt safety	Button to test the Battery Safety event. This will also trigger alarm pop-ups and the safety relay. After the test, use the "Relay close" button on the Monitoring tab to close the relay.		
Test stop charge	Button to test the Stop Charge event.		

## Events

With MasterBus a device can be programmed to initiate an action at another connected device. This is very helpful in automation of your system and is done by means of *event-based commands*.

In the Events tab you can program the MLI Ultra to act as an event source. Events which occur during the operation of the MLI Ultra will then trigger actions from other products.

Field	Description	Value
Event x source	Select an event that triggers an action, for example Relay open.	See <i>Event source</i> list
Event x target	Select the device that should act, for example the charger.	Selectable targets are system dependent
Event x command	Select the parameter that must be changed on the target device, for example No connection.	See command list of the selected device

Event x data

Data translates the input into an output.

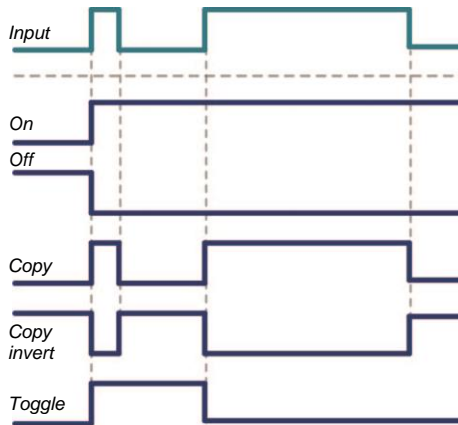

- On: status changes to On at first input signal.
- Off: status changes to Off at first input signal.
- Copy: status follows input signal.
- Copy invert: status follows opposite of input.
- Toggle: status changes at 1<sup>st</sup> signal and back at the 2<sup>nd</sup>.

## Events sources

Event source	Condition	Comments
Disabled	(no event programmed)	
Battery Safety	Battery Safety event occurred. At the same time the safety relay is triggered to disconnect the battery from loads and charger.	See page 25 for what to do if the safety relay has been triggered.
Stop charge	Battery voltage > 14.5V/29V (12V/24V battery), or voltage or temperature of one of the individual cells is too high.	Strongly recommended event! See the related step of the installation procedure.
Charging	Battery charging current > 1A	Indicates that the battery is being charged
Capacity low	State of Charge < <i>Capacity low</i>	See <i>Configuration tab - Event levels</i> for adjustment of the threshold level
Capacity very low	State of Charge < <i>Capacity very low</i>	See <i>Configuration tab - Event levels</i> for adjustment of the threshold level See the related step of the installation procedure.
Battery full	State of Charge > <i>Battery full</i> .	See <i>Configuration tab - Event levels</i> for adjustment of the threshold level
Battery > 20%	State of Charge > 19.5 %	
Battery > 40%	State of Charge > 39.5 %	
Battery > 60%	State of Charge > 59.5 %	
Battery > 80%	State of Charge > 79.5 %	
Battery 100%	State of Charge > 99.5 %	Can be used to control the LEDs on a MasterBus display for example
High temperature	Internal temperature of the MLI Ultra too high	See <i>Configuration tab - Event levels</i> for adjustment of the threshold level
Low temperature	Internal temperature of the MLI Ultra too low	See <i>Configuration tab - Event levels</i> for adjustment of the threshold level
Voltage low	Battery or cell voltage is too low.	See <i>Configuration tab - Event levels</i> for adjustment of the threshold level
Last time 100%	Last time the MLI Ultra was fully charged	See <i>Configuration tab - Event levels</i> for adjustment of the threshold level
Relay open	Relay has been opened, either by an event or by a user action	
Relay close	Relay has been closed, either by an event or by a user action	

## Event commands

When the MLI Ultra is configured as an *event target* by another device, this device can initiate an *event command* and an *event action* to be performed by the MLI Ultra.

Event command	Meaning
Relay open	The battery safety relay will be opened.
Relay close	The battery safety relay will be closed.

## Stop charge event

Before the battery reaches the limits of the operating specifications, the Stop Charge event is triggered. When configured (see page 15), this event forces the Mastervolt charger to switch off and resume charging after 10 minutes. The settings depend on the used charger because different chargers have different state options. Check the manual of the used charger for how to switch the charging state.

## Battery safety event

### PLEASE CAREFULLY READ THE FOLLOWING INFORMATION!

A battery safety event triggers the safety relay to automatically disconnect the battery from the loads and charging devices. There are two kinds of battery safety events: a resettable and a non-resettable.

#### • Resettable battery safety event

A resettable safety event occurs if the internal temperature of one of the individual cells exceeds 65°C / 149°F, or if the battery voltage level exceeds the minor minimum or maximum levels. See chapter 18 for details. This event is repeated every 60 seconds. It will only stop repeating if the battery voltage returns and remains within specifications:

Temperature of the cells	12V battery	24V battery
lower than 5°C / 41°F	11-15V	22-30V
higher than 5°C / 41°F	12-15V	24-30V

#### IF THE SAFETY RELAY HAS BEEN TRIGGERED:

1. On the MasterBus control panel, check that the voltage is within limits; higher than 10V (20V) and lower than 15.5V (31V) and within temperature range; 0°C - 50°C / 32°F – 122°F.
2. If within limits, click the "Close relay" button on the MasterBus control panel. Start charging if voltage is low (10V/20V) or discharging when high (15.5V/31V).
3. If the relay trips again, a non-resettable battery safety event occurred. **Do not try to force or reset the safety relay again! Isolate the battery and contact a Mastervolt representative.**

#### • Non-resettable battery safety event

A non-resettable safety event occurs if the internal temperature of one of the individual cells exceeds 75°C / 167°F, or if the voltage level exceeds the major minimum or maximum levels. See chapter 18 for details.

### WARNING!



IF A NON-RESETTING BATTERY SAFETY EVENT OCCURS: SET THE SAFETY RELAY(S) TO "LOCK OFF", SEE PAGE 12, AND CONTACT A MASTERVOLT REPRESENTATIVE FOR ASSISTANCE.

### How to activate MasterBus powering

1. Remove the DIP switch cover by loosening the four screws.
2. Use a small screwdriver to carefully set the DIP switches:
  - Set DIP switch 1 ON to select MasterBus.
  - Set DIP switch 2 ON to set MasterBus powering to *Automatic*.

The following picture is only an example!

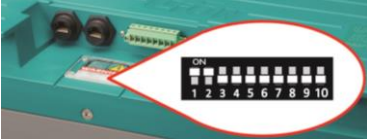

3. Replace the DIP switch cover and fasten with the screws. Make sure that the rubber band is placed correctly, to make it watertight.

In most cases this is the desired setting. MasterBus powering can also be set to *Always on*. This can only be selected in MasterAdjust. See MB power in section Configuration on page 20.

## 15. CZONE®

The CZone network is an NMEA 2000-compliant CAN-based system. In a CZone network, the MLI Ultra can be monitored from a remote panel like the Touch 5. The settings can only be adjusted with the CZone Configuration Tool. CZone integration will be available as of the next major firmware update.

### DIP switch settings

Use a small screwdriver to carefully set the CZone "Dipswitch Setting".

1. Remove the DIP switch cover by loosening the four screws.

The following picture is only an example!



2. Set DIP switch 1 to the OFF position.
3. Set DIP switch 2 to the OFF position.
4. Set DIP switches 3 to 10 to match the unique address used in the CZone network (see the CZone Configuration Tool Instructions manual).
5. Replace the DIP switch cover and fasten with the screws. Make sure that the rubber band is placed correctly, to make it watertight.

### Network wiring



- 1) MLI Ultra 1
- 2) MLI Ultra 2
- 3) Charger
- 4) Display
- 5) Drop cable
- 6) Drop cable
- 7) NMEA 2000 Network Terminating Resistor
- 8) NMEA 2000 Network Extension Cable
- 9) NMEA 2000 Network Single Tee Connector

Additional required materials per MLI Ultra:

- RJ45 Drop cable CZone/MB (included)
- Tee connector (not included)

### Adding the MLI Ultra to a CZone network

1. Disconnect the backbone at the closest backbone connection and add in a tee connector.
2. Reconnect the backbone connection(s) with the new tee connector in place.
3. Connect the RJ45 CZone/MB drop cable to the black coupler on the tee and then connect to the MLI Ultra. Ensure that the network is properly terminated. LED B (item 7 in figure *Main parts* on page 8) will blink to confirm CZone network identification.

## Configuration

Either do the configuration while connected to the network or use a prepared configuration file (.zcf). Ensure that a Dipswitch is assigned.



For detailed information on the configuration, please refer to the CZone® Configuration Tool Instruction manual, and section Configuration on page 20 which describes the parameters as shown in MasterAdjust.

### Adding the MLI Ultra to a CZone system configuration

**Precondition:** This section assumes that a CZone system is already configured and the CZone Configuration Tool is open.

In the CZone Configuration Tool, from the Modules tab, click the **Add** button.

1. Enter an understandable **Module Name**.
2. From the **Module Type** drop-down list, select **Battery (BAT)**.
3. Each device on a CZone network has a unique CZone address; the **Dipswitch**. This number must match the physical DIP switch settings. When connected to the system: either select one from the drop-down list or edit graphically.
4. From the **Battery Type** drop-down list, select the required model.
5. Option: click the **Advanced Settings** button to configure advanced options.

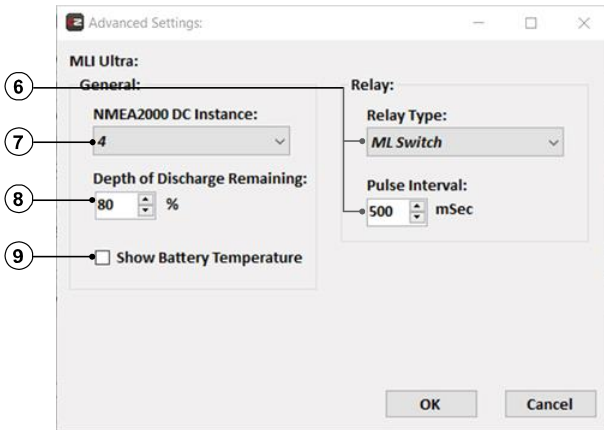

6. If required, select the required **Relay Type**. In most cases ML Switch works well. Select Daisy chain only for the secondary battery in a series connection (i.e. NOT the battery to which the relay is connected to).  
Select Advanced if you are not using the ML Switch relay. In this case you also need to set the Pulse Interval according to the manufacturer's specifications.
7. **NMEA2000 Instances** are used to differentiate between multiple monitoring sources.
8. To optimize the battery cycle life, the **Depth of Discharge Remaining (DoD)** is set to 80%.
 



**CAUTION!**  
Changing the DoD to 100% will decrease the cycle life.
9. Tick **Show Battery Temperature** to enable temperature monitoring.
10. Click **OK** to return to the Module Modification window and then click the **Alarm/Switch Settings** button.

Low Voltage:	On (V): 12,5	Delay (Sec): 10	Alarm Severities: None (No Alarm)
Battery Full:	On (%): 100		Alarm Severities: None (No Alarm)
Low Capacity:	10		Important
Very Low Capacity:	0		Critical (Most Severe)
Battery Level 1:	50		
Battery Level 2:	50		
Battery Level 3:	50		
Last Time 100%:	On (Days): 31		Alarm Severities: None (No Alarm)
Temperature High:	On (°C): 45		Alarm Severities: None (No Alarm)
Temperature Low:	5		None (No Alarm)
Battery Safety:			Alarm Severities: Critical (Most Severe)
Over Current:			Important
Relay Failure:			Critical (Most Severe)
Hardware Failure:			Critical (Most Severe)
			OK Cancel

11. Set the required alarm levels and Alarm Severities.

Battery level 1, 2 and 3 can be used for State of Charge switching.

12. Click **OK** to close the Battery Alarm/Switch Settings window.

13. Click **OK** to close the Module Modification window.

The following steps configure the safety behavior. For example, a *Stop Charge* switch that stops a battery charger.

**Note:** This must be done for all MLI Ultra units and for all charging devices.

14. Click on the **Circuits** tab and **Add** a new circuit (bottom left).

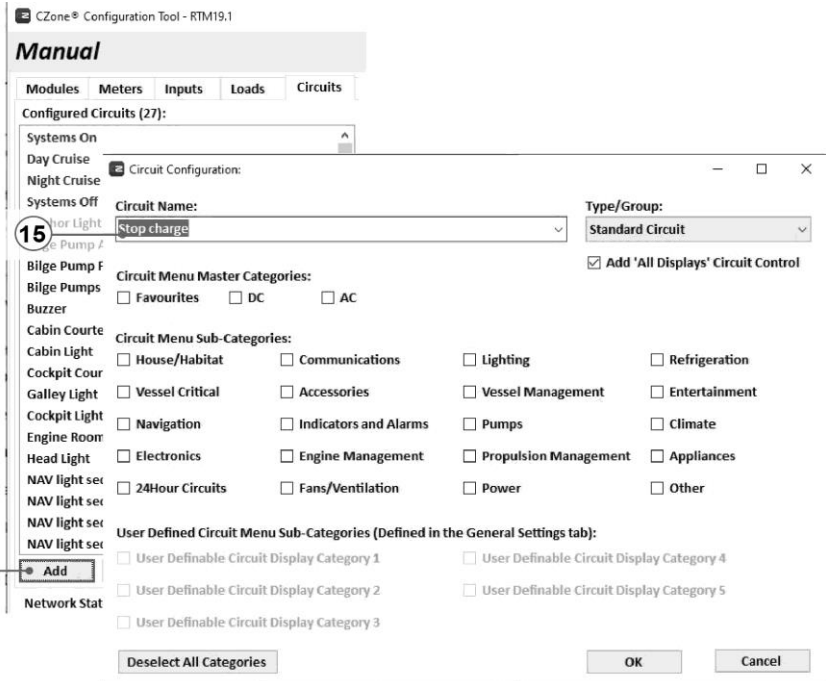

15. Enter the **Circuit Name** (e.g. Stop Charge) and click **OK**.

16. Click the **Add** button in the **Circuit Control** panel.

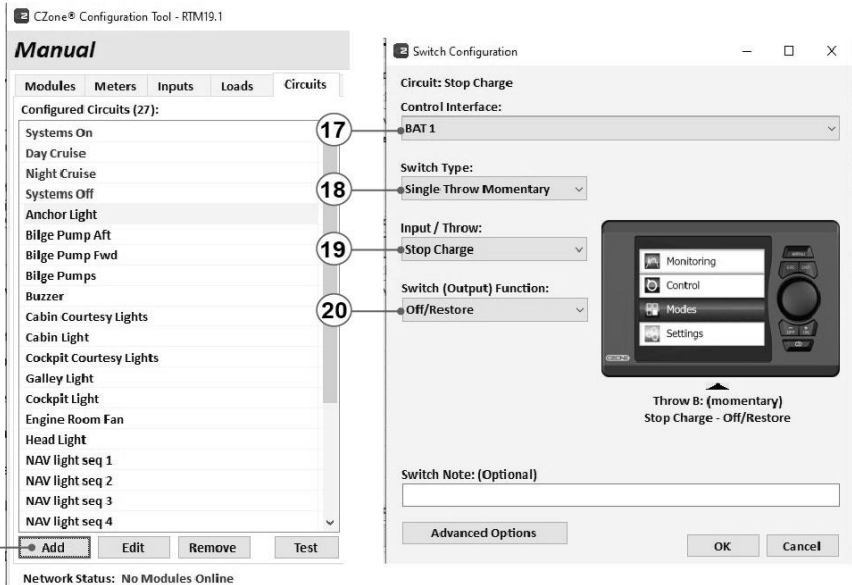

17. From the **Control Interface** drop-down list, select the required MLI Ultra unit.

18. From the **Switch Type** drop-down list, select **Single Throw Momentary**.

19. From the **Input / Throw** drop-down list, select **Stop Charge**.

20. From the **Switch (Output) Function** drop-down list, select **Off/Restore**.

21. Click **OK**.

Return to step 16 until all MLI Ultra units have this switch configured.

22. Click the **Add** button in the **Circuit Loads** panel.

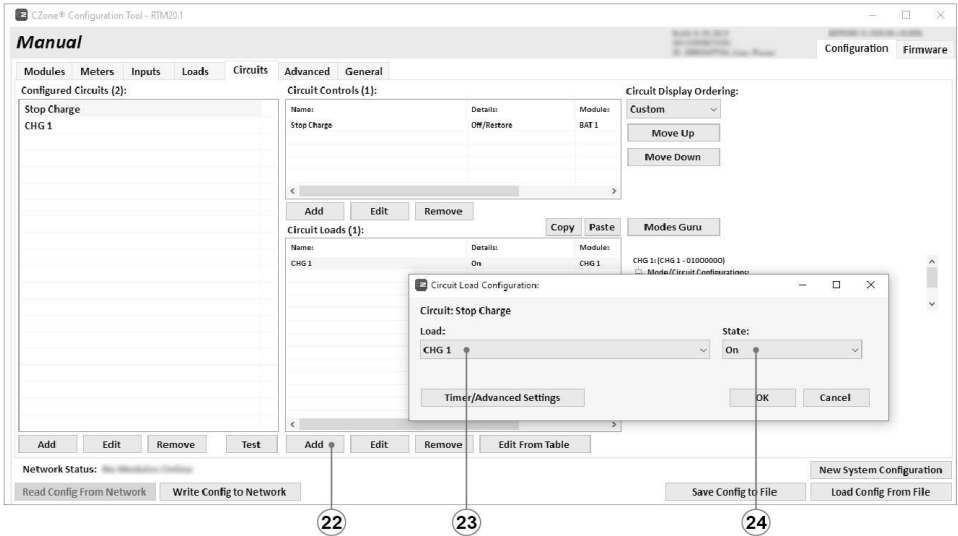

23. From the **Load** drop-down list, select the required charger.
24. Set the **State** to **On**.
25. Click **OK** to close the Circuit Load Configuration window.  
Optionally, return to step 22 to do this for all chargers.
26. Write the configuration to the network to use the new configuration.

## 16. BUILDING A BATTERY BANK



### CAUTION!

Only create multiple battery systems with batteries of the same type and capacity.

Make sure that all batteries are fully charged.

In case of replacing, make sure that the batteries have been charged and have the same product codes.

If connected in series, then two units can be protected by one safety relay.





If connected in parallel, then each unit requires its own safety relay!

Use properly sized fuses and wiring.

**Note:** Keep the various interconnect cables as short as possible and the same length. As you can see in the following figures, all short cables connecting the MLI Ultra units together, and all long cables are of equal length. The cables in question are marked by one or more slashes.

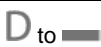

System parts	
A	MLI Ultra battery
B	Battery fuse in positive battery cable
C	Safety relay
D	MasterBus/CZone connection (see section Network wiring on pages 18 and 27)
E	MasterBus compatible charger
F	Fuse to protect the charger cable
G	Negative busbar
H	Positive busbar

Relay wires	Connect to	Description
(1) Red wire		Relay Control (RC) positive
(2) Brown wire		Close relay pulse
(3) Orange wire		Open relay pulse
(4) Black wire		RC minus
(5) Yellow wire		FeedBack signal relay
(8) Jumper wire (comes with MLI Ultra)		Relays connector detect, connect to RC minus

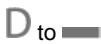

### Series connection with one 48V charger for two 24V batteries

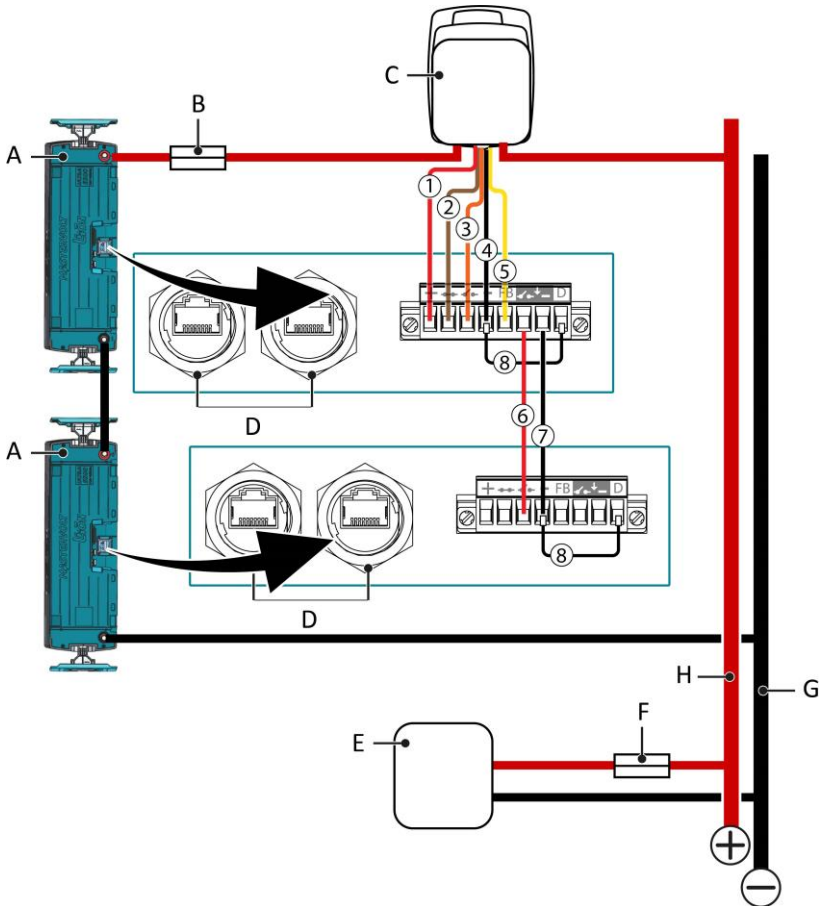









#### Notes:

- When two batteries share one ML Switch, for the secondary battery select the option Daisy chain from the Relay type drop down list. See section Configuration on page 20.
- The ML Switch supports up to two batteries in series. It is available in a 12V and a 24V version.
- As with all Lithium batteries, there is always some kind of unbalance present between the individual batteries. The unbalance must be as small as possible because the cell with the lowest capacity, limits the charge that a battery can deliver. When batteries are connected in series, this is even more critical which is why it is important to make sure that all batteries are fully charged before connecting them. After installation the MLI Ultra automatically keeps the batteries balanced. Balancing can take place during charging and idle mode.

### System parts

A	MLI Ultra battery
B	Battery fuse in positive battery cable
C	Safety relay
D	MasterBus / CZone connection (see sections Network wiring on pages 18 and 27)
E	MasterBus compatible charger
F	Fuse to protect the charger cable
G	Negative busbar
H	Positive busbar

Relay wires	Connect to		Description
(1) Red wire		on connector block A1	Relay Control (RC) positive
(2) Brown wire		on connector block A1	Close relay pulse
(3) Orange wire		on connector block A1	Open relay pulse
(4) Black wire		on connector block A1	RC minus
(5) Yellow wire	<b>FB</b>	on connector block A1	FeedBack signal relay
(6) Red (not included)	from 	on connector block A1	RC open relay from other battery
	to 	on connector block A2	
(7) Black (not included)	from 	on connector block A1	RC minus from other battery
	to 	on connector block A2	
(8) Jumper wire (included)	<b>D</b> to 	on connector block A1	Relays connector detect, connect to RC minus

## Set up clusters

Preconditions:

- ✓ All batteries are fully charged before connecting in series.
- ✓ The batteries have the same product code and software version.

**Note:** It is advisable to have the battery that is connected to the relay, configured as Primary battery.

A cluster of batteries (battery bank) can be created to be able to show a group of batteries as one, for monitoring the State Of Charge (SOC) for example. A clustered battery will show the (average) SOC of the cluster as a whole.

On monitoring panels such as the EasyView 5, only the Primary battery is shown on the main screen. In MasterAdjust, unfold the cluster (i.e. click the plus sign) to access the individual batteries if required.

Several batteries in series and/or parallel is called a cluster. A series string can be up to 10 devices. A cluster can contain up to 24 devices in total. The following figure explains the cluster topology.

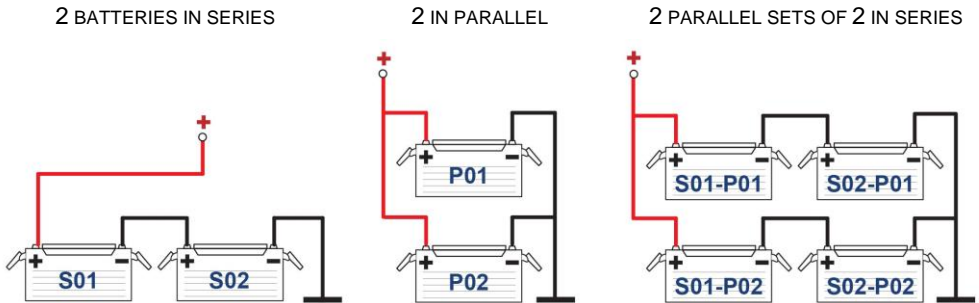

## How to create a cluster in MasterAdjust

When all batteries are connected to MasterBus, open MasterAdjust. The MLI Ultra will be recognized by the MasterBus network automatically.

1. Right-click USB:MasterBus... and select **Login**.
2. Select **Installer** and enter the installer code.
3. Select the MLI Ultra that will act as Primary and go to the **Configuration** tab.
4. Enter the number of batteries in the **# series (S)** field.  
If there are no batteries in series, enter 1.
5. Enter the number of batteries in parallel in the **# parallel (P)** field.  
If there are no batteries in parallel, enter 1.

6. Click the **Confirm topology** button.

Notice the status of the cluster topology. It can be:

- Approved;
- Needs approval: the topology was not confirmed;
- Not activated: the topology still requires activation;
- Too many devices/Double device/Incomplete/Missing self: the proposed topology is not possible or other units need to be selected.

Cluster

Nr. in series  
2

Nr. in parallel  
2

Confirm topology

Cluster topology  
Needs approval

After confirmation, the cluster topology is defined and fields to select the other units will appear. Note that S01-P01 is pre-filled with this unit but can be changed later.

7. In the **S01** field, from the drop-down list, select the serial number of the Primary battery. This battery will be the Cluster **Primary battery** and will show the Cluster state.
8. In the following fields, select the other clustered batteries.
9. Click the **Activate** button.

Confirm topology

Cluster status  
Missing self

Activate

Now, each battery will show its individual data in the monitoring tab while the Primary battery will show both the individual data and the data of the cluster.

Activation will fail if the battery is already in another cluster.

Series string 1

S01 - P01  
Select

S02 - P01  
Select

10. If required, select to base the displayed SOC on the lowest (minimum) instead of the average SOC in a cluster.
11. To activate voltage balancing of all cells in series, select ON from the Series balancing drop-down list.
12. **Series bulk** and **Series float** define the dynamic range for the complete cluster. Where, by default, Series bulk is  $14.25$  or  $28.5 \times$  number of batteries, and Series float is  $13.75$  or  $27.5 \times$  number of batteries.

SOC method  
Average

Series balancing  
On

Series bulk(V)  
28.0 V

Series float(V)  
27.0 V

To access the individual batteries, unfold the cluster (i.e. click the plus sign) in the left panel of MasterAdjust.

To identify the Primary battery, go to the configuration page of one of the (other) batteries.

To remove a battery from a cluster, click the **Detach** button on the Configuration tab of the battery in question.

To breakdown a cluster, in the configuration of the Primary battery: set the cluster to 1 (series) by 1 (parallel) and click the **Confirm topology** button.

## How to create a cluster in CZone

Preconditions: - a CZone system is already configured, including all batteries;  
- the CZone Configuration Tool opened the required configuration file.

1. In the CZone Configuration Tool, in the Modules tab, double-click the MLI Ultra that will act as Primary battery.
2. The Module Modifications window appears. Click the **Advanced Settings** button.
3. From the **Cluster Type** drop-down list, select **Cluster Primary**.
4. **Cluster DC Instance** is an NMEA2000 instance that is used to differentiate between multiple monitoring sources.
5. Enter a **Cluster Name**.
6. If the cluster is a series connection, tick **Set Relay type of all secondary batteries to Daisy Chain**.
7. Click the **Configure Topology** button.  
The Configured Battery Cluster Topology window appears.
8. Enter the number of batteries in series (S).  
If there are no batteries in series, enter 1.
9. Enter the number of batteries in parallel (P).  
If there are no batteries in parallel, enter 1.
10. To activate voltage balancing of all cells in series, select ON from the Series Balancing drop-down list.
11. Click the **OK** button to return to the Advanced Settings window.
12. Click the **OK** button to return to the Module Modifications window and then click the **Alarm/Switch Settings** button.
13. The Battery Alarm/Switch Settings window appears. To copy these settings from the Primary battery to all secondary batteries, tick **Apply to cluster**.
14. Keep clicking **OK** until all dialog windows have disappeared.
15. Write the configuration to the network to use the new configuration.

BAT 1	▼	BAT 2	▼
BAT 3	▼	BAT 4	▼
BAT 5	▼	BAT 6	▼

To identify the Primary battery, go to the Meters tab. The battery with two DC instances is the Primary battery.

## 17. TROUBLESHOOTING

Failure	Possible cause	What to do
No DC power available	A fuse has blown	Check all fuses and replace if necessary
	A cable or cable connection is defective	Check all cables and their connections. Replace if necessary.
	A relay has accidentally switched position.	Check all relays.
	The Battery Safety Event has triggered the safety relay.	Refer to chapter 14, page 25.
MasterBus display shows no MLI Ultra	The MasterView Easy has been configured to display selected devices only.	Check the option All devices or select the MLI Ultra to be displayed.
	Error in the wiring.	Check the MasterBus cables.
	No terminating device placed at the ends of the network.	MasterBus needs a terminating device on both ends of the network. Check if available.
	MasterBus network is configured as a ring network.	Ring networks are not allowed. Check the connections of the network.
	Batteries are completely empty.	Contact your Mastervolt dealer.
Overcurrent alarm	Too heavy load on the battery.	Battery current is >600A for more than 30 seconds. Reduce load immediately.
LED A is red on	An unrecoverable error occurred.	Contact your Mastervolt dealer.
LED B is yellow blinking	One short blink, long pause: Low State of Charge	Charge the battery.
	Two short blinks, long pause: CZone identification in progress	No action required.
	Steady blinking: firmware update in progress	No action required.

## 18. TECHNICAL DATA

### Technical specifications

	MLI Ultra 12/3000	MLI Ultra 12/6000	MLI Ultra 24/6000
Product code	66013000	66016000	66026000
Nominal voltage	12V	12V	24V
No load voltage, fully charged	13.2V	13.2V	26.4V
Nominal capacity (Cn)	230Ah	460Ah	230Ah
Nominal energy	3000Wh	6000Wh	6000Wh
Approximate weight	25.4 kg (56 lb)	46.4 kg (102 lb)	46.4 kg (102 lb)
Number of cells	4	8	8
Terminal type	Bolts M8	Bolts M8	Bolts M8
<b>Charge/discharge parameters</b>			
Charge voltage, Bulk/absorption phase <sup>1)</sup>	14.25V	14.25V	28.5V
Charge voltage, Float phase	13.5V	13.5V	27V
Maximum charge current	230A	460A	230A
Recommended charge current	≤ 80A	≤ 160A	≤ 80A
Maximum discharge current (20 minutes at 25°C / 77°F)	500A	500A	500A
Continuous discharge current	≤ 200A	≤ 300A	≤ 200A
Discharge cut-off voltage <sup>4)</sup>	11V	11V	22V
Required fuse	Max. 500A. Minimum DC breaking capacity (IR): 15kA		
Pulse current (10 sec)	2000A	2000A	2000A
<b>Rated capacity and cycle life</b>			
Rated capacity	230Ah	460Ah	230Ah
Cycle life	~3500 @ 80% DoD	~3500 @ 80% DoD	~3500 @ 80% DoD
<b>Dimensions</b>			
Length (L)	341±2mm / 22.3±0.1"	622±2mm / 24.5±0.1"	622±2mm / 24.5±0.1"
Width (W)	197±2mm / 7.8±0.1"	197±2mm / 7.8±0.1"	197±2mm / 7.8±0.1"
Height (H)	355±2mm / 14.0±0.1"	355±2mm / 14.0±0.1"	355±2mm / 14.0±0.1"
Installation angle	Upright (recommended) or on the long side		
<b>General</b>			
Parallel configuration	Yes, up to 24		
Series configuration	Yes, up to 10		
Operating temperature <sup>2) / 3)</sup>	-25 to 50°C / -13 to 122°F		
Nominal operating temp. <sup>3)</sup>	25°C / 77°F		
Storage temperature <sup>3)</sup>	-25 to 50°C / -13 to 122°F		
Self-discharge	< 4% per month @ 20°C / 68°F		
Warranty	2 years		
Protection degree	IP65 (electronics cabinet)		
Standards, approvals & listings	CE, E-Mark, RVIA, UN38.3, UL1642 (cells only)		

	MLI Ultra 12/3000	MLI Ultra 12/6000	MLI Ultra 24/6000
Chemistry	Lithium Iron Phosphate		
<b>Interfacing</b>			
MasterBus connectivity	Yes		
Powering capabilities for MasterBus	Yes		
CZone	Yes		
External disconnect switch	Yes, MANDATORY, direct connection for safety relay		
<b>Important available monitoring/events</b>			
Battery Safety event	Preventing unsafe overcharge, over discharge and overtemperature		
Stop Charge event	Communication to charging devices preventing overcharging		

1) If a Bulk/Absorption voltage of 14V is used (User Defined battery type), the Stop Charge Event is not required.

2) Charging at temperatures below -5°C / 23°F may result in battery not accepting charge current.

3) Temperatures below 5°C / 41°F and above 25°C / 77°F may affect lifetime and cycle life. See page 45.

4) Trigger point for battery safety event.

**Resettable battery safety event;** occurs when one of the following conditions is true:

12V battery	Any temperature:	>15V 10s
	<5°C / 41°F:	<10.75V 10s
	>10°C / 50°F:	<12V 10s
24V battery	Any temperature:	>30V 10s
	<5°C / 41°F:	<21.5V 10s
	>10°C / 50°F:	<24V 10s
Individual cell	Any temperature:	>4.0V 1s
	<5°C / 41°F:	<2.7V 10s or <2.4V 1s
	>10°C / 50°F:	<3.0V 10s or <2.7V 1s
	>65°C / 149°F:	Any voltage (immediate)



**Non-resettable battery safety event;** occurs when one of the following conditions is true:

12V battery	Any temperature:	>15.5V 1s
	<5°C / 41°F:	<10V 10s
	>10°C / 50°F:	<11V 10s
24V battery	Any temperature:	>31V 1s
	<5°C / 41°F:	<20V 10s
	>10°C / 50°F:	<22V 10s
Individual cell	Any temperature:	>4.2V 1s
	<5°C / 41°F:	<2.4V 10s or <2.2V 1s
	>10°C / 50°F:	<2.7V 10s or <2.5V 1s
	>75°C / 167°F:	Any voltage (immediate)



**CZone specifications**

LEN (Load Equivalence Number): 0

PGN (Parameter Group Number):

PGN	Description	Fields
127506	DC Detailed Status	State of Charge, Time remaining
127508	Battery Status	Battery Voltage, Battery Current, Battery Case Temperature

**Characteristics**

**Battery discharge characteristics and battery capacity at ambient temperature 25°C/77°F**

**Note:** the following graphics are based on new batteries.

- 12/3000

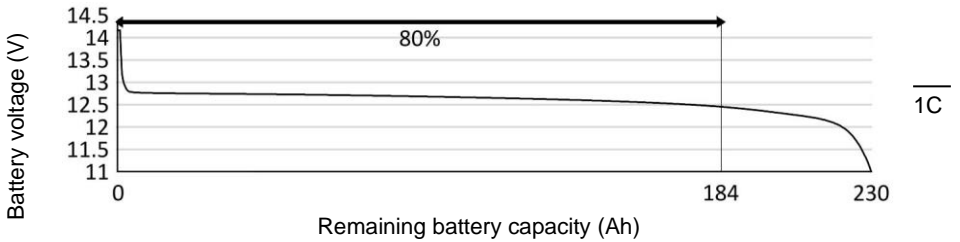

- 12/6000

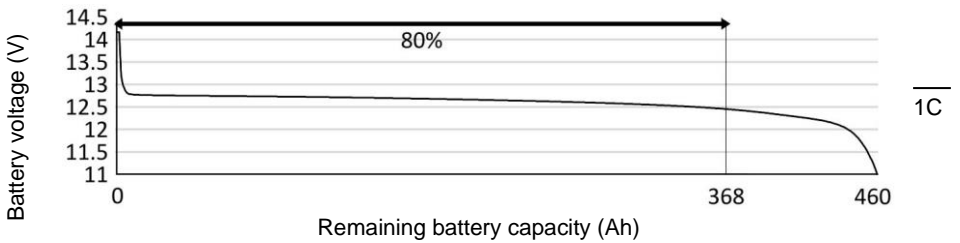

- 24/6000

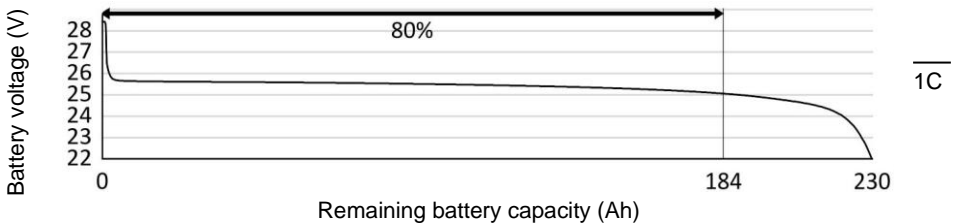

**Capacity retention over lifetime at ambient temperature 25°C/77°F**

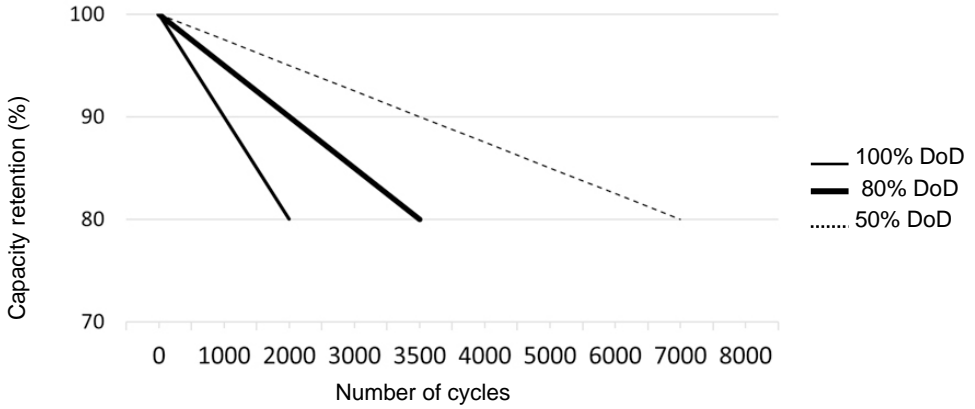

**Capacity retention at different cell temperatures**

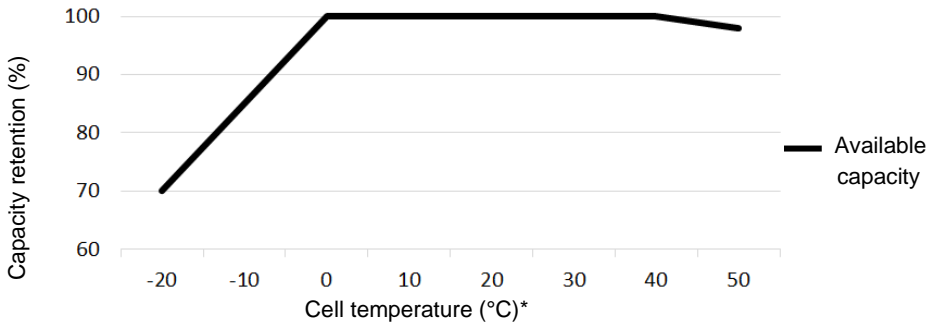

\* Cell temperatures are not necessarily equal to the ambient temperature of the battery!

**Cycle life retention at different ambient temperatures**

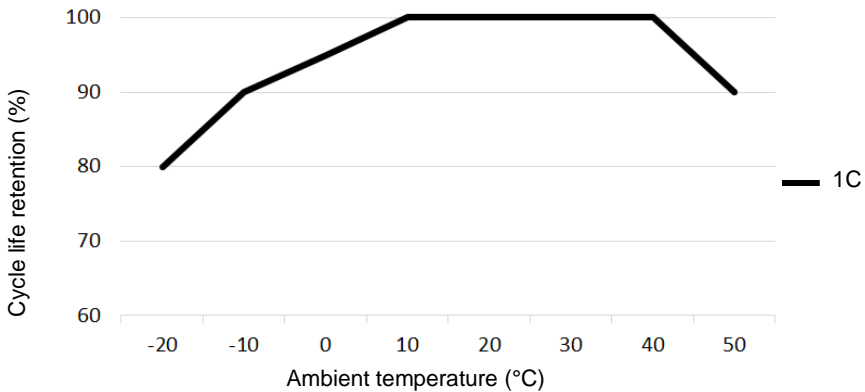

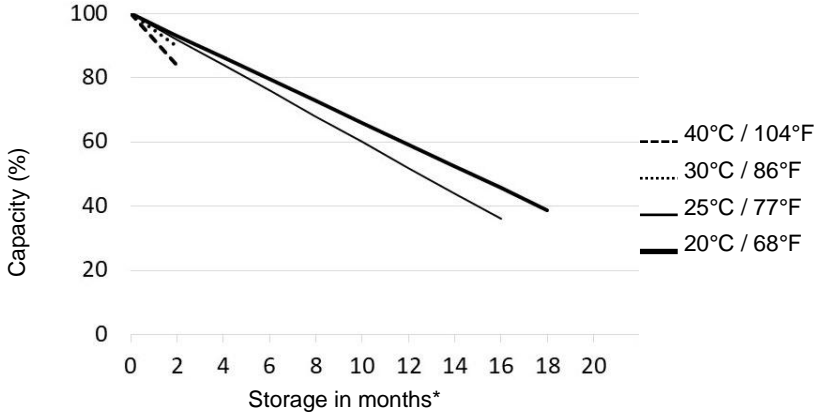
**Self-discharge in reflection to the storage temperature**

\* Provided that MasterBus power is off and there is no communication to the BMS.

**DIP switch settings**

DIP SWITCH	MEANING
1	1 = MasterBus 0 = CZone
2	1 = MasterBus power ON 0 = MasterBus power OFF or CZone
3 to 10	CZone's unique address (DIP switches 3 to 10 are not used in MasterBus)



We welcome your feedback and suggestions! Send feedback on this document to [info@mastervolt.com](mailto:info@mastervolt.com)

**Europe, Middle East & Africa**

**Technical Support**

T: +31 (0) 20 34 22 100

E: [ts.emea@OneASG.com](mailto:ts.emea@OneASG.com)

**Location & Shipping**

Navico Group EMEA

Snijdersbergweg 93

1105 AN Amsterdam

The Netherlands

**Americas & Caribbean**

**Technical Support**

T: +1 262 293 0600 / 800 307 6702

E: [tech.mastervolt@OneASG.com](mailto:tech.mastervolt@OneASG.com)

**Location & Shipping**

Navico Group US

N85 W12545 Westbrook Crossing

Menomonee Falls, WI 53051

United States

**Asia Pacific**

**Technical Support**

T: +64 9 415 7261

E: [technical.apac@OneASG.com](mailto:technical.apac@OneASG.com)

**Location & Shipping**

Navico Group APAC

42 Apollo Drive

Rosedale, Auckland 0632

New Zealand

*Document version: 10000019442/09 (June 24)*

*Copyright ©2024 Navico Group EMEA B.V. All rights reserved.*